

PART NR.
See parts table

COUNTRY OF ORIGIN:
Slovenia

STANDARDS:
REACH and RoHS compliant
DIN 17670 (contacts)
DIN 7985 (screws)
DIN 557 (nuts)
Flammability: UL94 V-0 (body)

CHARACTERISTICS

- Suits 2.5 mm² – 10mm² cable
- PA 6.6 GF-25 FR body material
- Robust cable interface, ring terminal screw connections
- Stackable, to create multi-position holder
- Clear cover optional

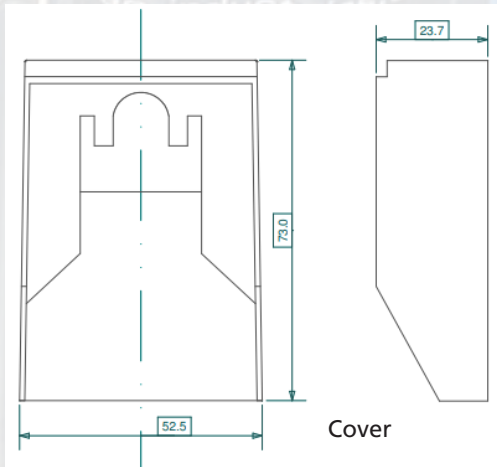
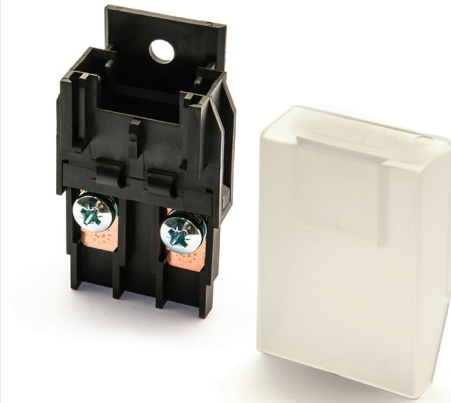
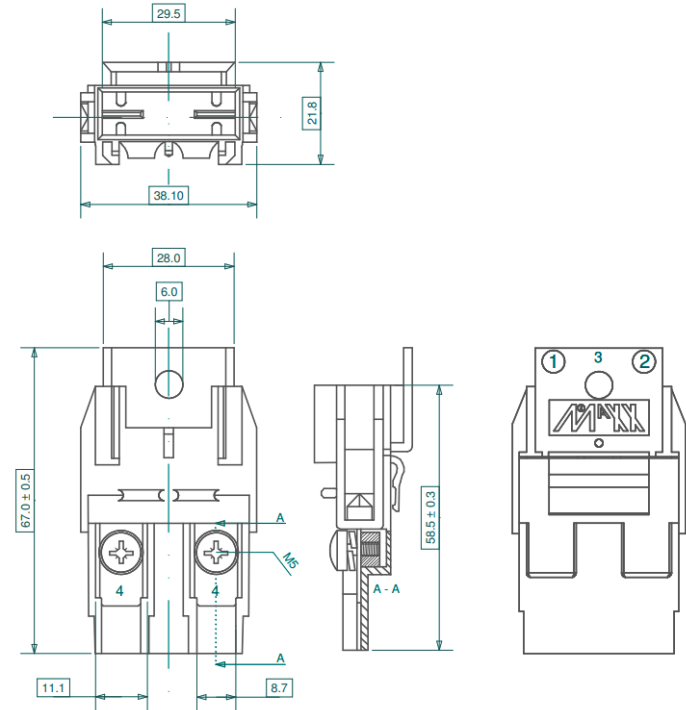

PHOTO / TECHNICAL DRAWING



maxiOTO FUSE HOLDER - CRIMP CONNECT



DIMENSIONS

L x W x H: 38,1 x 21,8 x 67 mm (body)
52,5 x 23,7 x 73 mm (cover)

PARTS TABLE

Part nr.	Description
FH9120	Holder for BF9000 series (1 position) PA 6.6 body, screw connect (M5 screws installed)
FH9105	Cover for use with FH9120
FH9100	Holder FH9120 incl. cover FH9105 (packed in bag)

TECHNICAL SPECIFICATIONS

Body: Ultramid A3X2G5, PA66-GF25 FR, black
 Cover: PP, translucent
 Contacts: CuFe 2P H130 (K65)
 Screws (M5x8): Galvanized steel grade 4.8
 Nuts (M5): CuZn 39 Pb3
 Suitable cable: 2,5~10 mm²