

PART NR.
See rating table

COUNTRY OF ORIGIN:
Germany

STANDARDS:
REACH and RoHS compliant
MB 10430-1
MBN 8820-3

CHARACTERISTICS

- Innovative, cost saving multi element fuse
- Single component with 1 input and 6 output terminals
- Complies to MB spec 10430-1
- Space savings compared to using miniOTO blade fuse
- Element visibility from sides, transparent fuse housings
- Blade rigidity through robust/sturdy body construction
- Safe and highly reliable/consistent operation with a single piece construction
- Self extinguishing transparent, color coded body materials
- High temperature resistive plastics used for fuse body materials
- Rating marked on top

PHOTO / TECHNICAL DRAWING

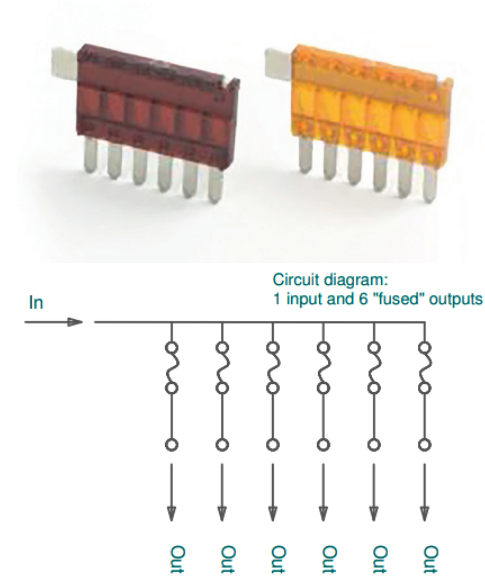

DIMENSIONS

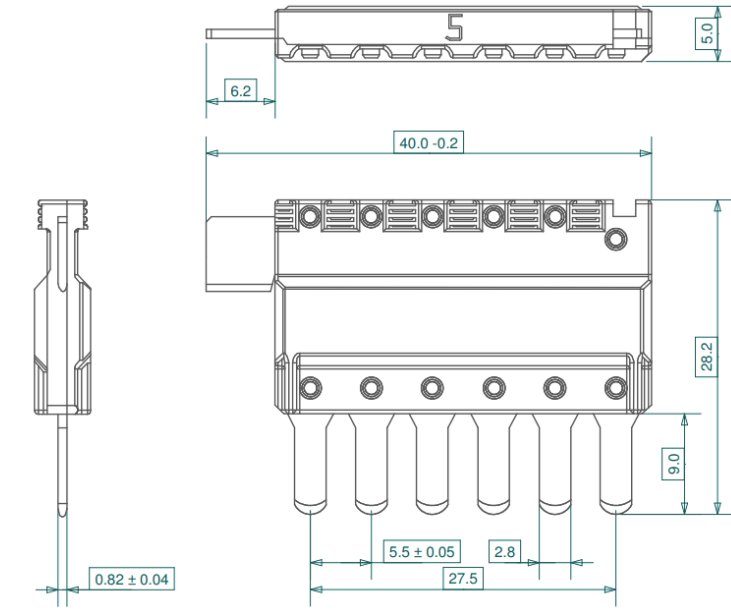

L x W x H: 40 x 5 x 28,2 (+9) mm

RATING TABLE

Part nr.	Color	Rating (A)	Rating (V)
BF7605	tan	5	32
BF7675	brown	7,5	32

TECHNICAL SPECIFICATIONS

Material body: PSU, color coded
Material element: Zinc, tin plated

FOR USE IN DAIMLER - MERCEDES BENZ VEHICLES

MB model	MB type	Year
ML	W166	> 2010
GLE	W167	> 2018
C	W205	> 2014
E	W213	> 2016
S	W222	> 2013
E-Coupe	W238	> 2016
GLC	W253	> 2015
G	W463	> 2012
Sprinter	W907	> 2014